

R100.00
[254]
TYPICAL

25
[63.5]

(25)
[63.5]

(30.71)
[78.03]

17-11/16
[44.90]

SIZE D	DRW. NO. 942306670-00	REV B
SCALE 1:1	DO NOT SCALE	SHEET 2 OF 2

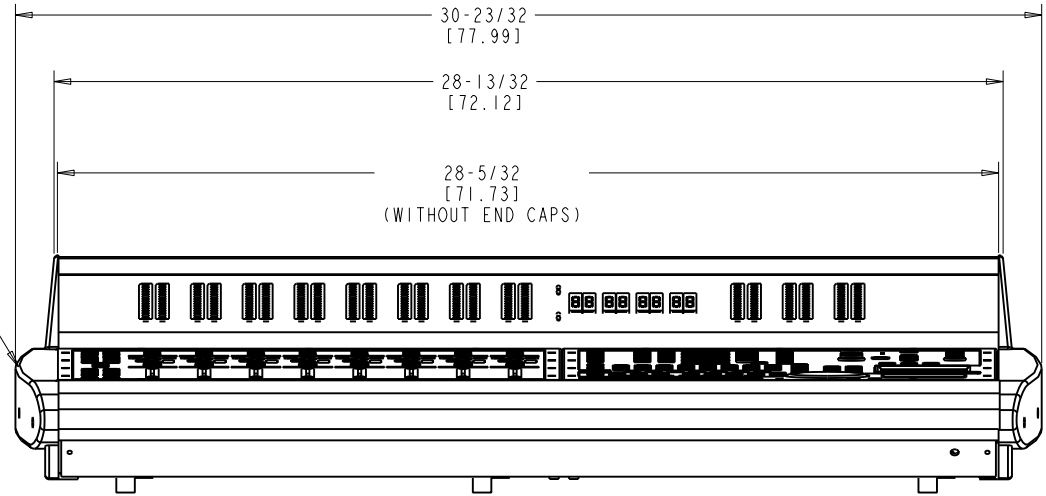
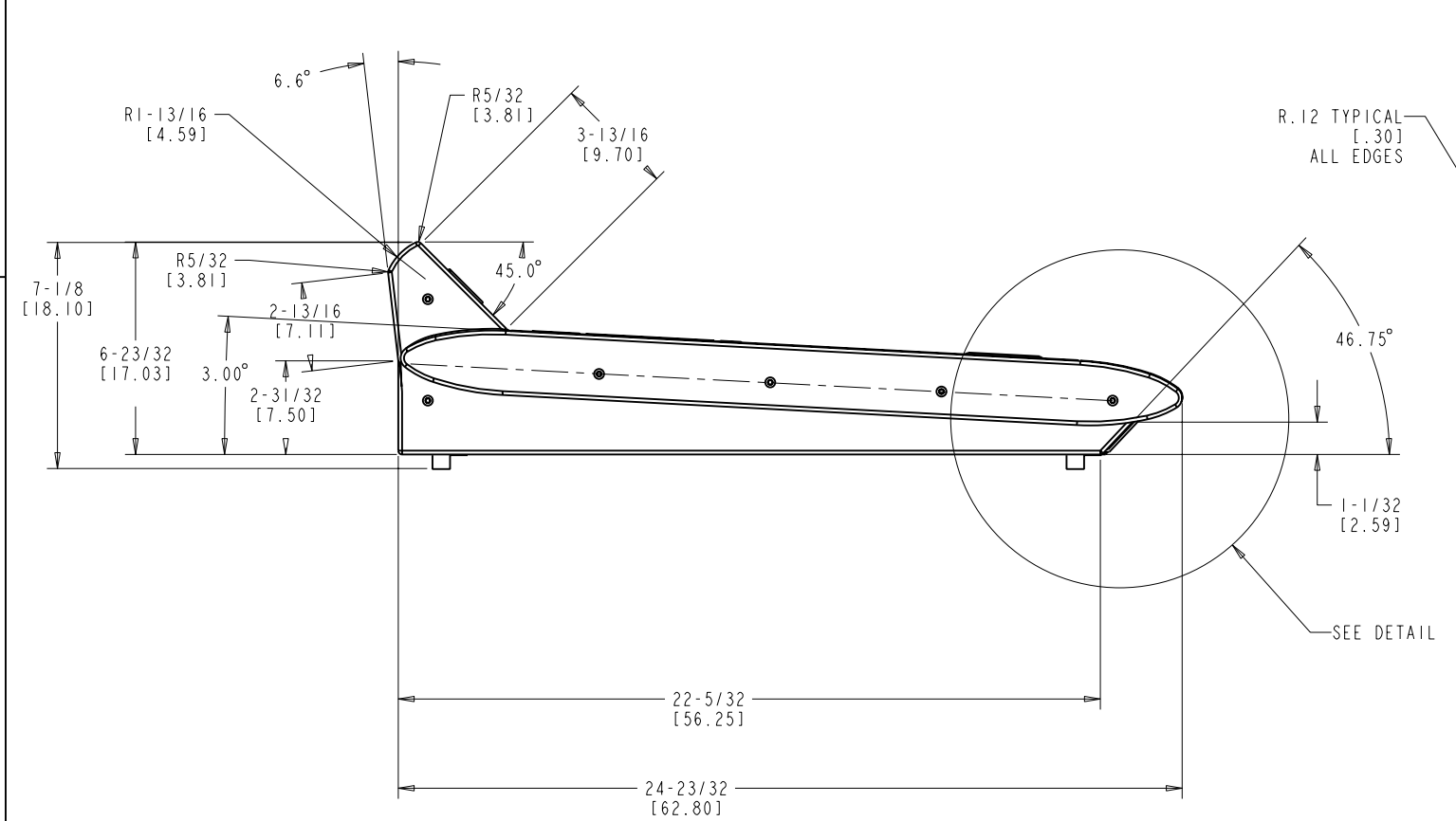

MAIN UNIT

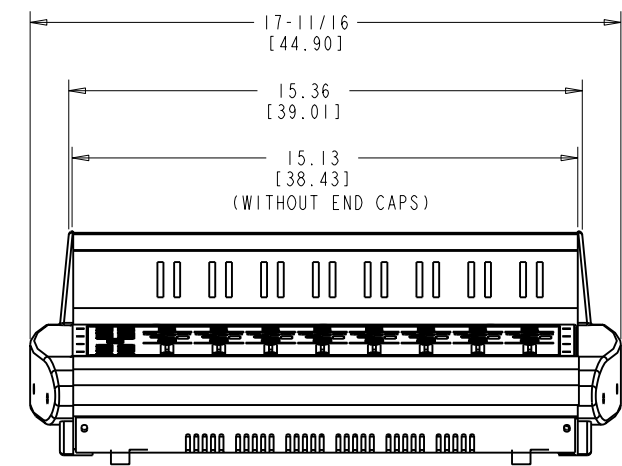

FADER EXPANSION UNIT

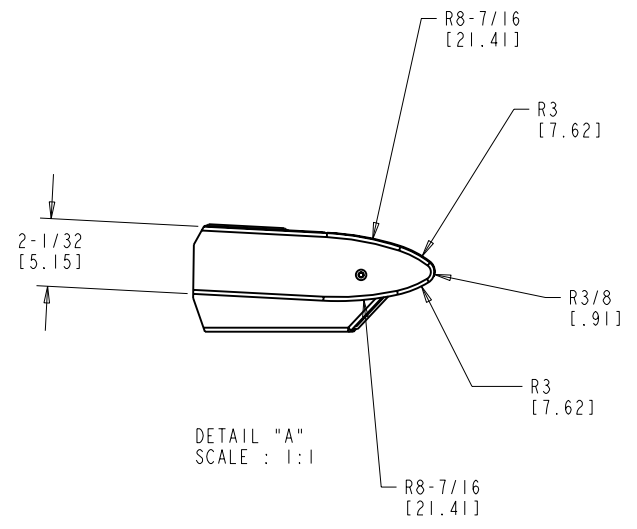

- NOTES: UNLESS OTHERWISE SPECIFIED.
- IT IS RECOMMENDED THAT THE UNIT NOT BE SUPPORTED BY THE PLASTIC END CAPS.
 - R=RADIUS

<p>The dimensions contained within are provided solely as a courtesy to our customers. All dimensions are given with +/- 1/32" accuracy. Digidesign reserves the right to change the dimensions of the ProControl chassis' and its components without notice. Digidesign, and its representatives, agents, and dealers are not liable and disclaim responsibility for the accuracy of information provided in this document. To ensure that the information provided meets your purposes, you are encouraged to examine the ProControl chassis and components at an authorized Digidesign dealer.</p>		<p>DIMENSION ARE IN INCHES (DIMENSIONS IN CENTIMETERS)</p> <p>TOLERANCE UNLESS OTHERWISE SPECIFIED DECIMALS 1 PLACE ± .005 2 PLACE ± .002 3 PLACE ± .001 ANGLES ± .005</p>		<p>digidesign A division of Avid</p>	
<p>PREPARED RPULIDO</p>	<p>DATE 9/8/98</p>	<p>FILENAME: FURNITURE_L1.DRW</p>	<p>PROCONTROL FURNITURE DRAWING</p>		
<p>CHECKED</p>	<p>DATE</p>	<p>MATERIAL</p>	<p>SIZE D</p>	<p>DRAWING NO. 942306670-00</p>	<p>REV B</p>
<p>APPROVED XXXXX</p>	<p>DATE XXXXXXXX</p>	<p>SCALE 3:8</p>	<p>DO NOT SCALE DRAWING</p>	<p>SHEET 1 OF 2</p>	