

SIZE D	DRW. NO. 942306670-00	REV A
SCALE 1:1 DO NOT SCALE		SHEET 2 OF 2

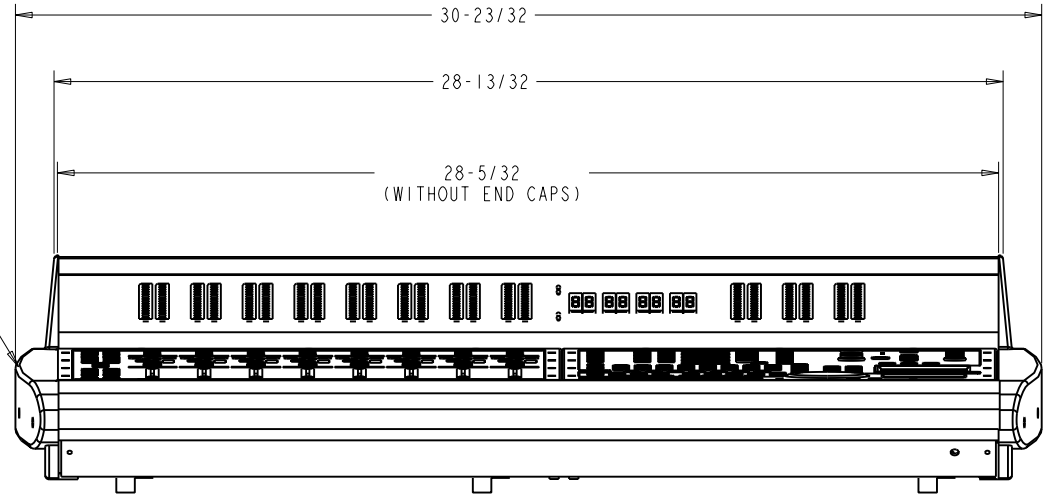

MAIN UNIT

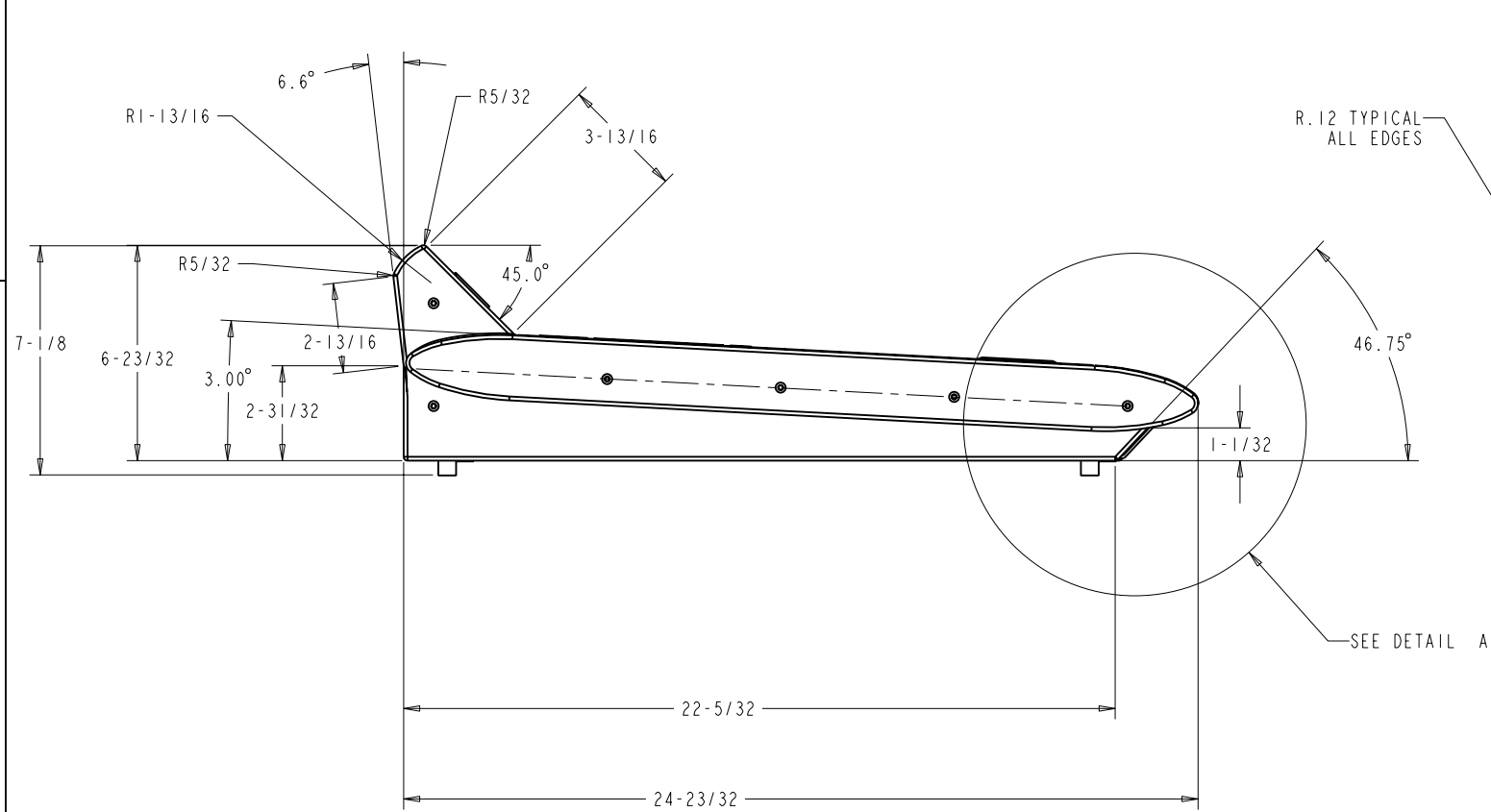
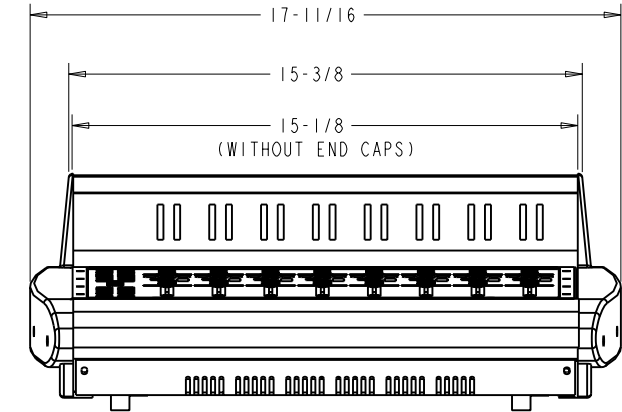

FADER EXPANSION UNIT

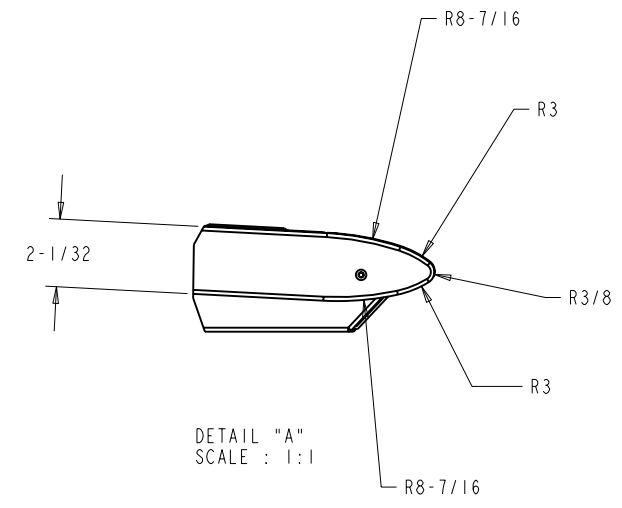

DETAIL "A"  
SCALE : 1:1

- NOTES: UNLESS OTHERWISE SPECIFIED.
- IT IS RECOMMENDED THAT THE UNIT NOT BE SUPPORTED BY THE PLASTIC END CAPS.
  - R=RADIUS

<p>The dimensions contained within are provided solely as a courtesy to our customers. All dimensions are given with +/- 1/32" accuracy. Digidesign reserves the right to change the dimensions of the ProControl chassis' and its components without notice. Digidesign, and its representatives, agents, and dealers are not liable and disclaim responsibility for the accuracy of information provided in this document. To ensure that the information provided meets your purposes, you are encouraged to examine the ProControl chassis and components at an authorized Digidesign dealer.</p>		<p>DIMENSION ARE IN INCHES TOLERANCE UNLESS OTHERWISE SPECIFIED</p> <p>DECIMALS 1 PLACE ± 1/16" 2 PLACE ± 1/32" 3 PLACE ± 1/64" ANGLES ± ----</p> <p>SURFACE ROUGHNESS ✓</p>		<p><b>digidesign</b> A division of <b>Avid</b></p>	
<p>PREPARED RPULIDO</p>	<p>DATE 9/8/98</p>	<p>FILENAME: FURNITURE_I.DRW</p>	<p>PROCONTROL FURNITURE DRAWING</p>		
<p>CHECKED</p>	<p>DATE</p>	<p>MATERIAL</p>	<p>SIZE D</p>	<p>DRAWING NO. 942306670-00</p>	<p>REV A</p>
<p>APPROVED XXXXX</p>	<p>DATE XXXXXXX</p>	<p>SCALE 3:8</p>	<p>DO NOT SCALE DRAWING</p>	<p>SHEET 1 OF 2</p>	